



DONG GUAN XINLONG SCIENCE & TECHNOLOGY CO., LTD

東莞新龍科技有限公司

NO: 5290

SPECIFICATION
承認書

Customer: _____

Description: PJ PHONE JACK

Part No: PJ-3518-L6G

Customer'S Part No: _____

Revision: _____

APPROVED BY	CHECKED BY	REVIEWED BY	PREPARED BY
周威			

CUSTOMER APPROVED:

地址：中国广东省东莞市塘厦镇莆心湖浦龙工业区

ADD: Pu Long Industrial Estate, PuXinHu ,TangXia Town ,DongGuan City, GuangDong Province China

TEL:86-769-87819555 87811966 FAX:86-769-87813682

RIPTION		DATE	
MODEL NO PJ-3518-L6G		日期: 2014年8月12日-	
RATING (额定值): DC 30V 0.5A			
PRACTICAL TEMPERATURE RANGE 使用温度范围	-16~65° C 在-16° C~+65° C 温度内使用		
STANDARD ATMOSPHEIC CONDITIONS 测试标准状况	UNLESS OTHERWISE SPECIFIED THE STANDARD RANGE OF ATMOSPHERIC CONDITIONS FOR MAKING MEASUREMENTS AND TESTS ARE AS FOLLOWS: (1) BETWEEN BODY AND CONDUCTOR: 5° C TO 35° C (2) BETWEEN CONDUCTORS NOT TO BE CONTACT: 45% TO 85% (3) PRESSURE: 86Kpa TO 106Kpa 在没有指定的情况下测试温度、湿度、气压如下: (1) 温度为 5° C~35° C (2) 湿度为 45%~85% (3) 气压为 86 Kpa~106Kpa		
MECHANICAL (机械性能)			
ITEM 项目		TEST CONDITIONS 测试条件	PERFORMANCE 规格
1	CONNECTION FORCE 插入力度	MEASUREMENT SHALL BE MADE AFTER CONNECTING AND DISCONNECTING USING STANDARD PLUG GAUGE 3 TIMES。 依据标准的 PLUG GAUGE 做第 3 次拔插后测定	3~30N
	DISCONNECTI ON FORCE 拔出力度	MEASUREMENT SHALL BE MADE AFTER CONNECTING AND DISCONNECTING USING STANDARD PLUG GAUGE 3 TIMES。 依据标准的 PLUG GAUGE 做第 3 次拔插后测定	3~30N
2	TERMINAL STRENGTH 端子强度	A STATIC LOAD OF 0.1N/m(1kgf/cm)SHALL BE APPLIED TO THE TIP OF THE TERMINAL FOR 1 MIN IN ANY DIRECTION 向排脚先端的任意一个方向加 1 分钟 0.1N/m(1kgf/cm)的力度。	THERE SHALL BE NO DAMAGE TO THE TERMINAL SUCH AS CRACKS, LOOSENESS OR PLAY ELECTRICAL ,AND MECHANICAL CHARACTERISTICS SHALL BE SATISFIED 在排脚中没有裂开、松动等异常，满足于机械、电气性能
ELECTRICAL (电气性能)			
ITEM 项目		TEST CONDITIONS 测试条件	PERFORMANCE 规格
3.1	CONTACT RESISTANCE 接触电阻	MEASURED AT SMALL CURRENT (100m A OR LESS) 1000Hz 在微小电流 (100 m A) 以下测试	$\leq 0.03 \Omega$
3.2	INSULATION RESISTANCE 绝缘电阻	APPLY A VOLTAGE OF 500V DC FOR 1 MIN TO FOLLOWING PORTIONS AFTER WHICH MEASUREMENT SHALL BE MADE: (1) BETWEEN BODY AND CONDUCTOR (2) BETWEEN CONDUCTORS NOT TO BE CONTACT (3) BETWEEN CONDUCTORS NOT TO BE WHEN PLUG IS INSERTED DC 500V 1 MIN 输入 500V DC 电压 1 分钟，按以下接触方法测试: (1) 插座体与排脚之间 (2) 不接触的排脚之间 (3) 插头插入时不接触排脚之间	$\geq 100M \Omega$

MODEL NO:
PJ-3518-L6G

3.3	DIELECTRIC STRENGTH 耐电压	<p>AC 500V 5ms(50~60Hz)FOR 1 MIN TRIP CURRENT:0.5mA</p> <p>(1) BETWEEN BODY AND CONDUCTOR</p> <p>(2) BETWEEN CONDUCTORS NOT TO BE CONTACT</p> <p>(3) BETWEEN CONDUCTORS NOT TO BE WHEN PLUG IS INSERTED DC 500V 1 MIN</p> <p>输入 AC 500V (50Hz) /min 电压 1 分钟感度电流为 0.5mA, 按以下接触方法测试:</p> <p>(1) 插座体与排脚之间</p> <p>(2) 不接触的排脚之间</p> <p>(3) 插头插入时不接触排脚之间</p>	<p>WITHOUT DAMAGE TO PARTS ARCING OR BREAKDOWN ETC</p> <p>没有绝缘破坏等异常</p>
-----	----------------------------	--	---

URABILITY (耐久性)

ITEM 项目	TEST CONDITIONS 测试条件	PERFORMANCE 规格
4. 1	<p>SOLDERABILITY TEST 可焊性试验</p> <p>THE TOP OF THE TERMINALS SHALL BE DIPPED 1mm IN THE SOLDER BATH OF 240±5°C FOR 3±0.5 SECONDS</p> <p>端子顶部被浸入锡池中 1mm 深,温度为 240±5°C,时间为 3±0.5 秒</p>	<p>(1) SOLDER WETTING TIME SHALL BE 3 SEC OR LESS 焊接时间应少于 3 秒</p> <p>(2) THE AREA OF SOLDERING SHOULD BE OVER 95% 焊接面积应有 95%以上</p>
4.2	<p>RESISTANCE TO SOLDERING HEAT TEST 耐焊性试验</p> <p>REFLOW SOLDERING CONDITIONS: PREHEAT:TEMPERATURE ON THE COPPER FOIL SURFACE SHOULD REACH 180°C.120S AFTER THE P.C.B ENTERED INTO THE SOLDERING EQUIPMENT. TALLEST TEMPERATURE:TEMPERATURE ON THE COPPER FOIL SURFACE SHOULD REACH THE PEAK TEMPERATURE OF 260±5°C WITH IN 20 SECONDS.</p> <p>过回流焊条件: 预热:电镀层表面的温度应达到 180°C,120s 后电路板进入回流焊设备。 最高温度:电镀层表面温度最高为 260±5°C且停留不超过 20 秒。</p>	<p>WITHOUT DEFOR MATION OF CASE OR EXCESSIVE LOOSENESS OF TEMINALS ELECTRICAL CHARACTERISTICS SHALL BE SATISFIED</p> <p>本体无变形, 满足于机械、电气性能</p>

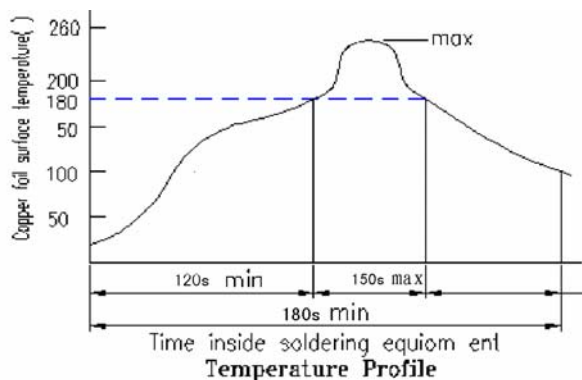

MODEL NO: PJ-3518-L6G

4. 3	RESISTANCE TO SOLDERING HEAT TEST 耐焊性试验	SOLDERING IRON METHOD: BIT TEMPERATURE $330 \pm 5^{\circ}\text{C}$ APPLICATION TIME OF SOLDERING IRON 3 ± 0.5 SEC HOWEVER EXCESSIVE PRESSURE SHALL NOT BE APPLIED TO THE TERMINAL 手焊接的时候温度需控制在 $330 \pm 5^{\circ}\text{C}$, 时间为 3 ± 0.5 秒, 但不能在排脚上施加异常压力。	WITHOUT DEFORMATION OF CASE OR EXCESSIVE LOOSENESS OF TEMINALS ELECTRICAL CHARACTERISTICS SHALL BE SATISFIED 本体无变形, 满足于机械、电气性能
4. 4	HUMIDITY TEST 潮湿试验	THE JACK SHALL BE STORED AT A TEMPERATURE OF $40 \pm 2^{\circ}\text{C}$ AND A HUMIDITY OF 90% TO 96% FOR 96 Hr. THEN THE JACK SHALL BE MAINTAINED AT STANDARD ATMOSPHERIC CONDITION FOR 1 Hr FOR OTHER PROCEDURES 放置 $40 \pm 2^{\circ}\text{C}$ 的相应湿度为 90~96% Hr 环境中 96 小时后, 再将样板放在正常环境中 1 小时后进行测试	THERE SHALL BE NO DAMAGE ON APPEARANCE. MECHANICAL AND ELECTRICAL CHARACTERISTICS SHALL BE SATISFIED 外观无异常, 满足于机械、电气性能。
4.5	HEAT TEST 耐热试验	THE JACK SHALL BE STORED AT A TEMPERATURE OF $70 \pm 2^{\circ}\text{C}$ FOR 96 HOURS, AND THEN IT SHALL BE SUBJECTED TO THE CONTROLLED RECOVERY MBASURBM 放置在温度 $70 \pm 2^{\circ}\text{C}$ 中测试 96 小时后, 再放置正常室温中 1 小时来测定	
4. 6	COLD TEST 耐寒试验	THE JACK SHALL BE STORED AT A TEMPERATURE OF $-25 \pm 3^{\circ}\text{C}$ FOR 96 HOURS AND THEN IT SHALL BE SUBJECTED TO THE CONTROLLED RECOVERY CONDITIONS FOR 1 HOUR AFTER WHICH 放置在温度 $-25 \pm 3^{\circ}\text{C}$ 中 96 小时后, 再放置常温常湿中 1 小时来测定	THERE SHALL BE NO DAMAGE ON APPEARANCE MECHANICAL AND ELECTRICAL CHARACTERISTICS SHALL BE SATISFIED 外观无异常, 满足于机械、电气性能
4. 7	LIFE TEST 寿命试验	WITHOUT LOAD CONNECTION AND DISCONNECTION SHALL BE MADE WITH THE MATING PLUGS AND JACKS FOR 5, 000 CYCLES AT A SPEED OF 10 TO 25 CYCLES/MIN 无负荷 将结合了的标准 Plug(尽量要近于中心的)在 1 分钟内以 10~25 的速度, 进行 5, 000 次插入, 拔出 LOAD: AT RATING CONDITION (NON-INDUCTIVE LOAD) CONNECTION AND DISCONNECTION SHALL BE MADE 1,000 CYCLES AT A SPEED 10 TO 20 CYCLES / MIN 负荷 以定格状态(无诱导负荷)在 1 分钟内以 10~20 次的速度进行 1,000 次插入、拔出	(1) CONTACT RESISTANCE SHALL BE $\leq 0.1 \Omega$ (2) DISCONNECTION FORCE SHALL BE 3 TO 30N (3) MECHANICAL AND ELECTRICAL CHARACTERISTICS SHALL BE SATISFIED (1) 接触电阻 $\leq 0.1 \Omega$ (2) 拔出力是 3~30N (3) 其它:满足于机械、电气性能

MODEL NO: PJ-3518-L6G

ENVIRONMENTAL (环境性能)		
ITEM 项目	TEST CONDITIONS 测试条件	PERFORMANCE 规格
4.8 SALT MIST TEST 盐雾测试	<p>1. TESTING BATH: THE TEMPERATURE SHALL $35^{\circ}\text{C} \pm 2^{\circ}\text{C}$ IN THE AMBIENT OF THE SPECIMEN DURING THE TEST.</p> <p>2. SPRAY APPARAUS: THE APPARATUS SHALL CAPABLE OF PRODUCING FINE DENSE MIST UNIFORMLY.</p> <p>3. SALT WATER: THE CONCENTRATION OF THE SALT WATER SHALL ADJUSTED AT $5 \pm 1\%$ WEIGHT RATIO AT $35^{\circ}\text{C} \pm 2^{\circ}\text{C}$.</p> <p>4. TESTING TIME 24 ± 0.5 HOURS. AFTER WASHED IN WATER . THE SAMPLE SHALL LEFT ALONE FOR 1 OR 2 HOURS IN A ROOM AMBIENT.</p> <p>1. 测试容器: 在测试过程中, 产品周围环境温度 $35^{\circ}\text{C} \pm 2^{\circ}\text{C}$。</p> <p>2. 喷雾设备: 盐雾要均匀喷出。</p> <p>3. 盐水: 盐水要在 $35^{\circ}\text{C} \pm 2^{\circ}\text{C}$ 温度条件下, 调整在 $5 \pm 1\%$ 比例范围内。</p> <p>4. 测试时间: 24 ± 0.5 小时 清洗后, 样品在室内要单独放置 1 至 2 个小时。</p>	<p>APPEARANCE SHALL NOT EXTREMELY RUST. AND CONTACTING PORTIONS SHOULD SUCH THAT THEY WILL WORK WITHOUT HINDRANCE FOR PRACTICAL USE.</p> <p>表面不能有严重的腐蚀, 接触部分要不防碍正常使用。</p>

4.9 TEMPERATURE CYCLING TEST 温度循环测试	<p>THE JACK SHALL BE SUB JECTED TO 5 CYCLES OF THE FOLLOWING CONDITIONS SHOWN IN THE FIGURE, AND THEN SHALL RETURNED ALLOWED TO REMAIN IN ROOM AMBIENT CONDITION FOR 30 MINUTES</p> <p>将插座以下列条件作 5 个循环, 然后放回室内环境 30 分钟</p> <p>Temp($^{\circ}\text{C}$)</p> <p>(Hours)</p>	<p>THERE SHALL BE NO DEFORMATION OR CRACKS IN MOLDED PART.</p> <p>INSERTION & EXTRACTION FORCE: 3 TO 30N</p> <p>CONTACT RESISTANCE: MAX. $30\text{m}\Omega$</p> <p>INSULATION RESISTANCE: MIN. $100\text{M}\Omega$</p> <p>DIELECTRIC WITHSTANDING VOLTAGE: 500VAC/MIN (BETWEEN TERMINALS)</p> <p>产品不能变形与破裂</p> <p>插拔力: 3N 至 30N</p> <p>接触电阻: 最大 $30\text{m}\Omega$</p> <p>绝缘电阻: 最小 $100\text{M}\Omega$</p> <p>绝缘耐压: 最小 500VAC (端子之间)</p>
---	--	--

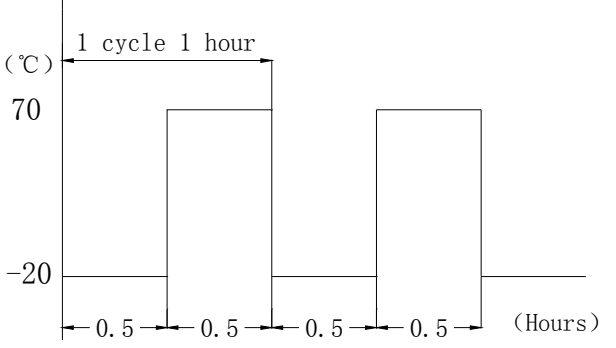
5.0	<p>COLD&HEAT SHOCK TEST 冷热冲击测试</p>	<p>THE JACK SHALL BE SUBJECTED TO 5 CYCLES OF THE FOLLOWING CONDITIONS SHOWN IN THE FIGURE, AND THEN SHALL RETURN AND ALLOWED TO REMAIN IN ROOM AMBIENT CONDITION FOR 30 MINUTES 将插座以下列条件作 5 个循环，然后放回室内环境 30 分钟</p> <p>TEMP (°C)</p>  <p>(Hours)</p>	<p>THERE SHALL BE NO DEFORMATION OR CRACKS IN MOLDED PART. INSERTION & EXTRACTION FORCE: 3 TO 30N CONTACT RESISTANCE: MAX. 30MΩ INSULATION RESISTANCE: MIN. 100 MΩ DIELECTRIC WITHSTANDING VOLTAGE: 500VAC/MIN (BETWEEN TERMINALS)</p> <p>产品不能变形与破裂 插拔力: 3N 至 30N 接触电阻: 最大 30mΩ 绝缘电阻: 最小 100 MΩ 绝缘耐压: 最小 500VAC (端子之间)</p>
-----	--	---	--

制 表	校 对	审 核	备注:
		周威	共 6 页

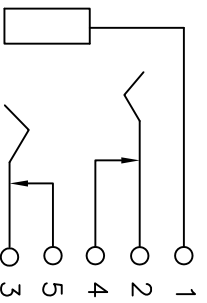
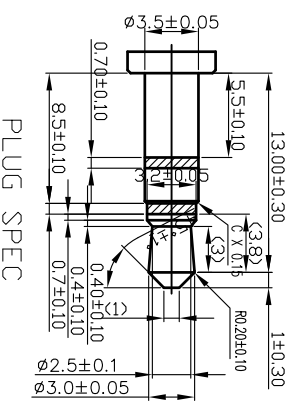
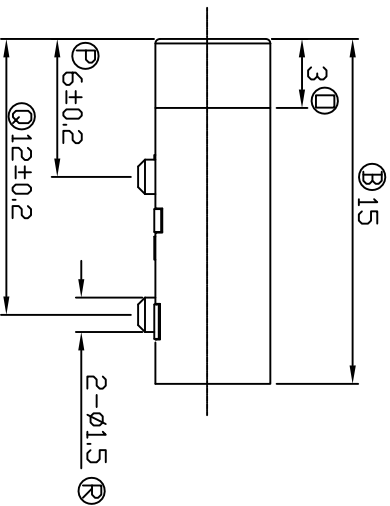
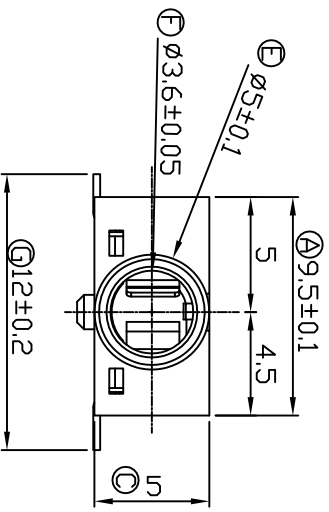
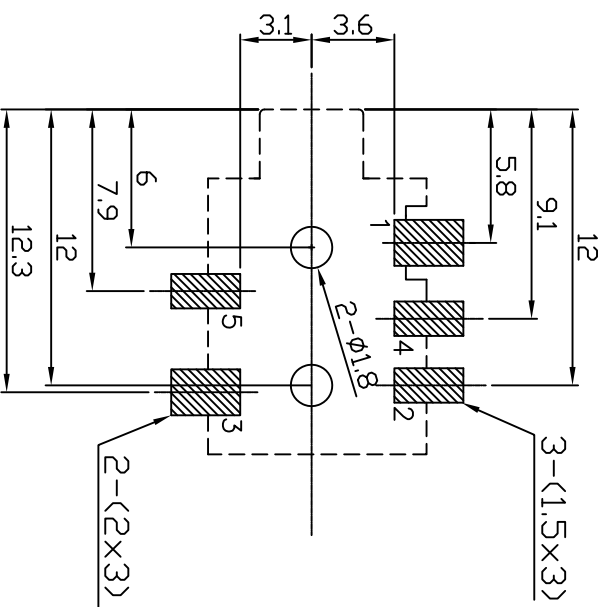
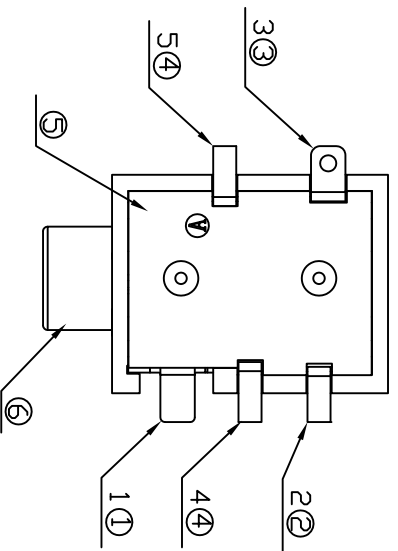
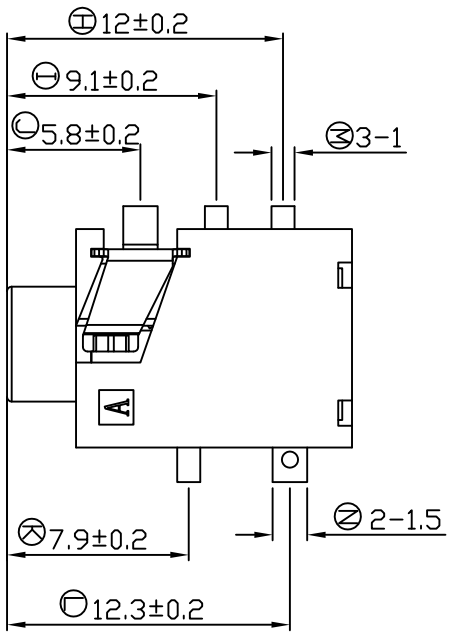

CIRCUIT DIAGRAM

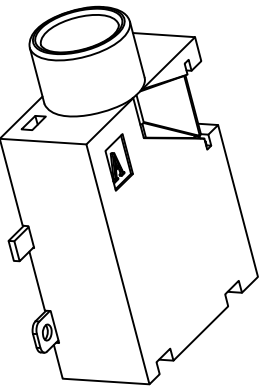

Marker	Describe	Data	DSND
UNSPECIFIED TOLERANCE	≤4 ±0.15	4-16 ±0.20	≥16 ±0.30
		ANGULAR ±5°	

No.	PART NAME	QTY	MATERIAL (THICK, COLOR)	DSND	DATE	CHKD	DATE	VIEW:	CAT. NO.	NAME:
①	HOUSING: PJ-PJ-3518-1.6	1	PA-9T(BLACK)	Mei Xia	2010.05.27			3:1	PJ-3518-L6G GP	EARPHONE JACK
②	COVER: PC-PJ-3518-1.6	1	PA-9T(BLACK)	CHKD						
③	TERMINAL: MT-PJ-3518-4Q.6	2	PHOSPHOR BRONZE: t=0.30	APVD						
④	TERMINAL: MT-PJ-3518-4Q.6	1	PHOSPHOR BRONZE: t=0.20							
⑤	TERMINAL: MT-PJ-3518-2Q.6	1	PHOSPHOR BRONZE: t=0.20							
⑥	TERMINAL: MT-PJ-3518-1Q.6	1	PHOSPHOR BRONZE: t=0.30							
										REMARK

NOTE:
A,B,C... : 重点管控尺寸, 生产时每天均需测量;
其它: 一般尺寸, 每次生产时均需测量。



DONGGUAN XINLONG SCIENCE&TECHNOLOGY CO., LTD.

DWN. NO. Q/XL-QM-001A-0006 B0

Test Report

No. CANEC1400258802

Date: 14 Jan 2014

Page 1 of 8

SHENZHEN BAO SHIDA PLASTIC PRODUCTS CO.,LTD.

NO.3 JIANG BIAN INDUSTRY PARK CENTRE ROAD,SONGGANG TOWN,BAOAN DISTRICT,SHENZHEN CHINA

The following sample(s) was/were submitted and identified on behalf of the clients as : PA9T

SGS Job No. : CP14-000376 - SZ
Date of Sample Received : 07 Jan 2014
Testing Period : 07 Jan 2014 - 13 Jan 2014
Test Requested : Selected test(s) as requested by client.
Test Method : Please refer to next page(s).
Test Results : Please refer to next page(s).
Conclusion : Based on the performed tests on submitted samples, the results of Lead, Mercury, Cadmium, Hexavalent chromium, Polybrominated biphenyls (PBB), Polybrominated diphenyl ethers (PBDE) comply with the limits as set by RoHS Directive 2011/65/EU Annex II; recasting 2002/95/EC.

Signed for and on behalf of
SGS-CSTC Ltd.



Yan Lee
Approved Signatory



This document is issued by the Company subject to its General Conditions of Service printed overleaf, available on request or accessible at <http://www.sgs.com/en/Terms-and-Conditions.aspx> and, for electronic format documents, subject to Terms and Conditions for Electronic Documents at <http://www.sgs.com/en/Terms-and-Conditions/Terms-e-Documents.aspx>. Attention is drawn to the limitation of liability, indemnification and jurisdiction issues defined therein. Any holder of this document is advised that information contained hereon reflects the Company's findings at the time of its intervention only and within the limits of Client's instructions, if any. The Company's sole responsibility is to its Client and this document does not exonerate parties to a transaction from exercising all their rights and obligations under the transaction documents. This document cannot be reproduced except in full, without prior written approval of the Company. Any unauthorized alteration, forgery or falsification of the content or appearance of this document is unlawful and offenders may be prosecuted to the fullest extent of the law. Unless otherwise stated the results shown in this test report refer only to the sample(s) tested.

Test Results :

Test Part Description :

Specimen No.	SGS Sample ID	Description
SN1	CAN14-002588.002	Black plastic grains

Remarks :

- (1) 1 mg/kg = 1 ppm = 0.0001%
- (2) MDL = Method Detection Limit
- (3) ND = Not Detected (< MDL)
- (4) "-" = Not Regulated

RoHS Directive 2011/65/EU

- Test Method :
- (1)With reference to IEC 62321-5:2013, determination of Cadmium by ICP-OES.
 - (2)With reference to IEC 62321-5:2013, determination of Lead by ICP-OES.
 - (3)With reference to IEC 62321-4:2013, determination of Mercury by ICP-OES.
 - (4)With reference to IEC 62321:2008, determination of Hexavalent Chromium by Colorimetric Method using UV-Vis.
 - (5)With reference to IEC 62321:2008, determination of PBBs and PBDEs by GC-MS.

<u>Test Item(s)</u>	<u>Limit</u>	<u>Unit</u>	<u>MDL</u>	<u>002</u>
Cadmium (Cd)	100	mg/kg	2	ND
Lead (Pb)	1,000	mg/kg	2	ND
Mercury (Hg)	1,000	mg/kg	2	ND
Hexavalent Chromium (CrVI)	1,000	mg/kg	2	ND
Sum of PBBs	1,000	mg/kg	-	ND
Monobromobiphenyl	-	mg/kg	5	ND
Dibromobiphenyl	-	mg/kg	5	ND
Tribromobiphenyl	-	mg/kg	5	ND
Tetrabromobiphenyl	-	mg/kg	5	ND
Pentabromobiphenyl	-	mg/kg	5	ND
Hexabromobiphenyl	-	mg/kg	5	ND
Heptabromobiphenyl	-	mg/kg	5	ND
Octabromobiphenyl	-	mg/kg	5	ND
Nonabromobiphenyl	-	mg/kg	5	ND
Decabromobiphenyl	-	mg/kg	5	ND
Sum of PBDEs	1,000	mg/kg	-	ND
Monobromodiphenyl ether	-	mg/kg	5	ND



This document is issued by the Company subject to its General Conditions of Service printed overleaf, available on request or accessible at <http://www.sgs.com/en/Terms-and-Conditions.aspx> and, for electronic format documents, subject to Terms and Conditions for Electronic Documents at <http://www.sgs.com/en/Terms-and-Conditions/Terms-e-Documents.aspx>. Attention is drawn to the limitation of liability, indemnification and jurisdiction issues defined therein. Any holder of this document is advised that information contained hereon reflects the Company's findings at the time of its intervention only and within the limits of Client's instructions, if any. The Company's sole responsibility is to its Client and this document does not exonerate parties to a transaction from exercising all their rights and obligations under the transaction documents. This document cannot be reproduced except in full, without prior written approval of the Company. Any unauthorized alteration, forgery or falsification of the content or appearance of this document is unlawful and offenders may be prosecuted to the fullest extent of the law. Unless otherwise stated the results shown in this test report refer only to the sample(s) tested.

Test Report

No. CANEC1400258802

Date: 14 Jan 2014

Page 3 of 8

<u>Test Item(s)</u>	<u>Limit</u>	<u>Unit</u>	<u>MDL</u>	<u>002</u>
Dibromodiphenyl ether	-	mg/kg	5	ND
Tribromodiphenyl ether	-	mg/kg	5	ND
Tetrabromodiphenyl ether	-	mg/kg	5	ND
Pentabromodiphenyl ether	-	mg/kg	5	ND
Hexabromodiphenyl ether	-	mg/kg	5	ND
Heptabromodiphenyl ether	-	mg/kg	5	ND
Octabromodiphenyl ether	-	mg/kg	5	ND
Nonabromodiphenyl ether	-	mg/kg	5	ND
Decabromodiphenyl ether	-	mg/kg	5	ND

Notes :

- (1) The maximum permissible limit is quoted from the directive 2011/65/EU, Annex II.

Hexabromocyclododecane (HBCDD)

Test Method : Determination of HBCDD by GC-MS based on IEC 62321:2008.

<u>Test Item(s)</u>	<u>Unit</u>	<u>MDL</u>	<u>002</u>
Hexabromocyclododecane (HBCDD)	mg/kg	10	ND

Notes :

- (1) Reference Information: Directive 2011/65/EU recasting RoHS directive 2002/95/EC:
Hexabromocyclododecane (HBCDD) is considered as a priority for risk evaluation and substance restriction.

Phthalate

Test Method : Determination of phthalates by GC-MS based on EN 14372:2004.

<u>Test Item(s)</u>	<u>CAS NO.</u>	<u>Unit</u>	<u>MDL</u>	<u>002</u>
Dibutyl Phthalate (DBP)	84-74-2	%(W/W)	0.003	ND
Benzylbutyl Phthalate (BBP)	85-68-7	%(W/W)	0.003	ND
Bis-(2-ethylhexyl) Phthalate (DEHP)	117-81-7	%(W/W)	0.003	ND



This document is issued by the Company subject to its General Conditions of Service printed overleaf, available on request or accessible at <http://www.sgs.com/en/Terms-and-Conditions.aspx> and, for electronic format documents, subject to Terms and Conditions for Electronic Documents at <http://www.sgs.com/en/Terms-and-Conditions/Terms-e-Documents.aspx>. Attention is drawn to the limitation of liability, indemnification and jurisdiction issues defined therein. Any holder of this document is advised that information contained hereon reflects the Company's findings at the time of its intervention only and within the limits of Client's instructions, if any. The Company's sole responsibility is to its Client and this document does not exonerate parties to a transaction from exercising all their rights and obligations under the transaction documents. This document cannot be reproduced except in full, without prior written approval of the Company. Any unauthorized alteration, forgery or falsification of the content or appearance of this document is unlawful and offenders may be prosecuted to the fullest extent of the law. Unless otherwise stated the results shown in this test report refer only to the sample(s) tested.

Notes :

- (1) Reference Information: Directive 2011/65/EU recasting RoHS directive 2002/95/EC:
Bis (2-ethylhexyl) phthalate (DEHP), Butyl benzyl phthalate (BBP) and Dibutyl phthalate (DBP) are considered as a priority for risk evaluation and substance restriction.



This document is issued by the Company subject to its General Conditions of Service printed overleaf, available on request or accessible at <http://www.sgs.com/en/Terms-and-Conditions.aspx> and, for electronic format documents, subject to Terms and Conditions for Electronic Documents at <http://www.sgs.com/en/Terms-and-Conditions/Terms-e-Documents.aspx>. Attention is drawn to the limitation of liability, indemnification and jurisdiction issues defined therein. Any holder of this document is advised that information contained hereon reflects the Company's findings at the time of its intervention only and within the limits of Client's instructions, if any. The Company's sole responsibility is to its Client and this document does not exonerate parties to a transaction from exercising all their rights and obligations under the transaction documents. This document cannot be reproduced except in full, without prior written approval of the Company. Any unauthorized alteration, forgery or falsification of the content or appearance of this document is unlawful and offenders may be prosecuted to the fullest extent of the law. Unless otherwise stated the results shown in this test report refer only to the sample(s) tested.

ATTACHMENTS

RoHS Testing Flow Chart

- 1) Name of the person who made testing: Michael Tso / Cutey Yu
- 2) Name of the person in charge of testing: Adams Yu / Yolanda Wei
- 3) These samples were dissolved totally by pre-conditioning method according to below flow chart (Cr⁶⁺ and PBBs/PBDEs test method excluded).

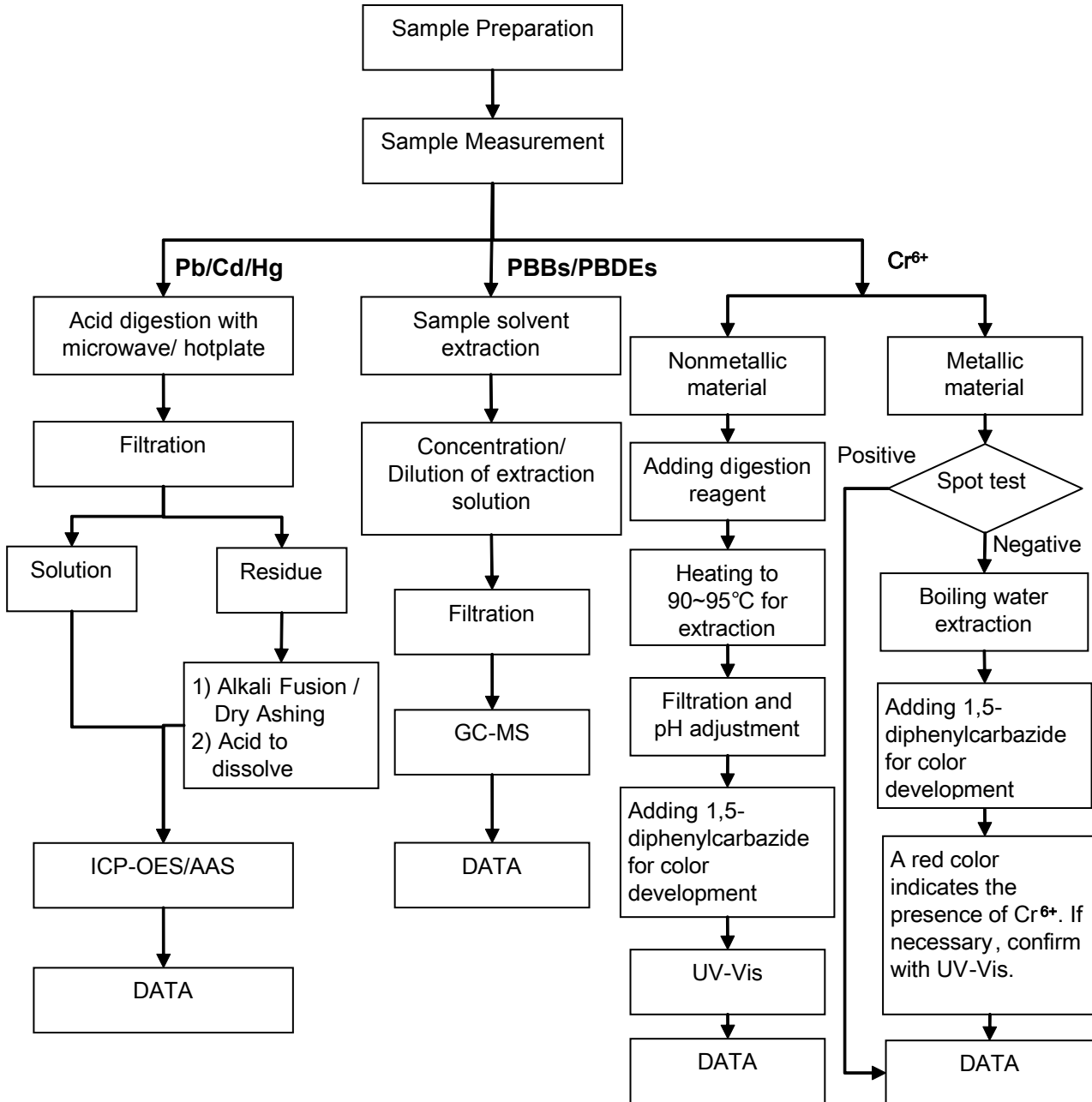

This document is issued by the Company subject to its General Conditions of Service printed overleaf, available on request or accessible at <http://www.sgs.com/en/Terms-and-Conditions.aspx> and, for electronic format documents, subject to Terms and Conditions for Electronic Documents at <http://www.sgs.com/en/Terms-and-Conditions/Terms-e-Documents.aspx>. Attention is drawn to the limitation of liability, indemnification and jurisdiction issues defined therein. Any holder of this document is advised that information contained hereon reflects the Company's findings at the time of its intervention only and within the limits of Client's instructions, if any. The Company's sole responsibility is to its Client and this document does not exonerate parties to a transaction from exercising all their rights and obligations under the transaction documents. This document cannot be reproduced except in full, without prior written approval of the Company. Any unauthorized alteration, forgery or falsification of the content or appearance of this document is unlawful and offenders may be prosecuted to the fullest extent of the law. Unless otherwise stated the results shown in this test report refer only to the sample(s) tested.

ATTACHMENTS

HBCDD Testing Flow Chart

- 1) Name of the person who made testing: Cutey Yu
- 2) Name of the person in charge of testing: Yolanda Wei

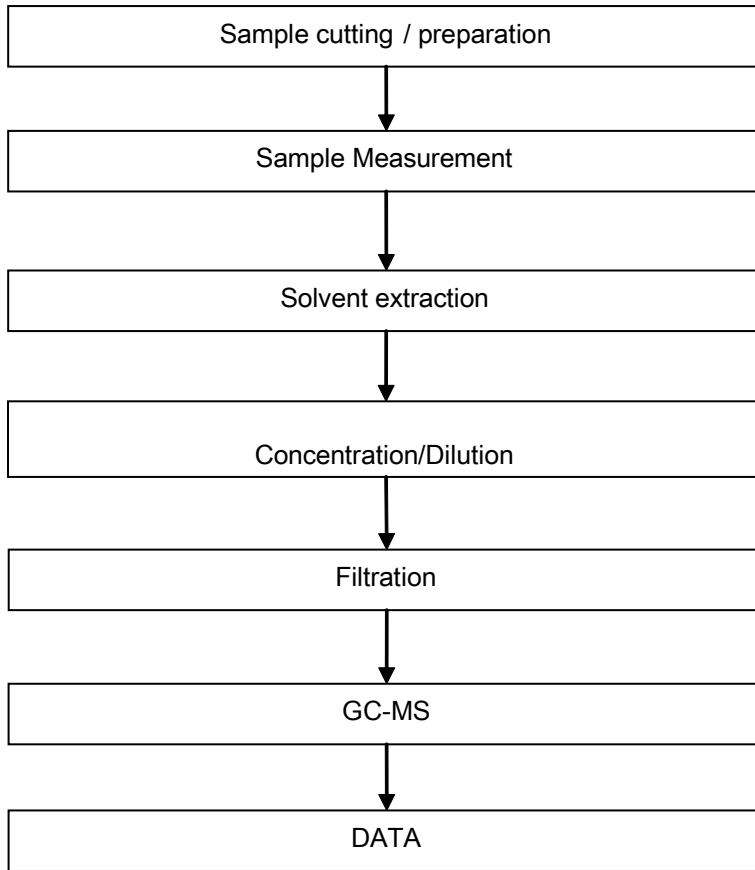

This document is issued by the Company subject to its General Conditions of Service printed overleaf, available on request or accessible at <http://www.sgs.com/en/Terms-and-Conditions.aspx> and, for electronic format documents, subject to Terms and Conditions for Electronic Documents at <http://www.sgs.com/en/Terms-and-Conditions/Terms-e-Documents.aspx>. Attention is drawn to the limitation of liability, indemnification and jurisdiction issues defined therein. Any holder of this document is advised that information contained hereon reflects the Company's findings at the time of its intervention only and within the limits of Client's instructions, if any. The Company's sole responsibility is to its Client and this document does not exonerate parties to a transaction from exercising all their rights and obligations under the transaction documents. This document cannot be reproduced except in full, without prior written approval of the Company. Any unauthorized alteration, forgery or falsification of the content or appearance of this document is unlawful and offenders may be prosecuted to the fullest extent of the law. Unless otherwise stated the results shown in this test report refer only to the sample(s) tested.

ATTACHMENTS

Phthalates Testing Flow Chart

- 1) Name of the person who made testing: Liu Qiong
- 2) Name of the person in charge of testing: Yolanda Wei

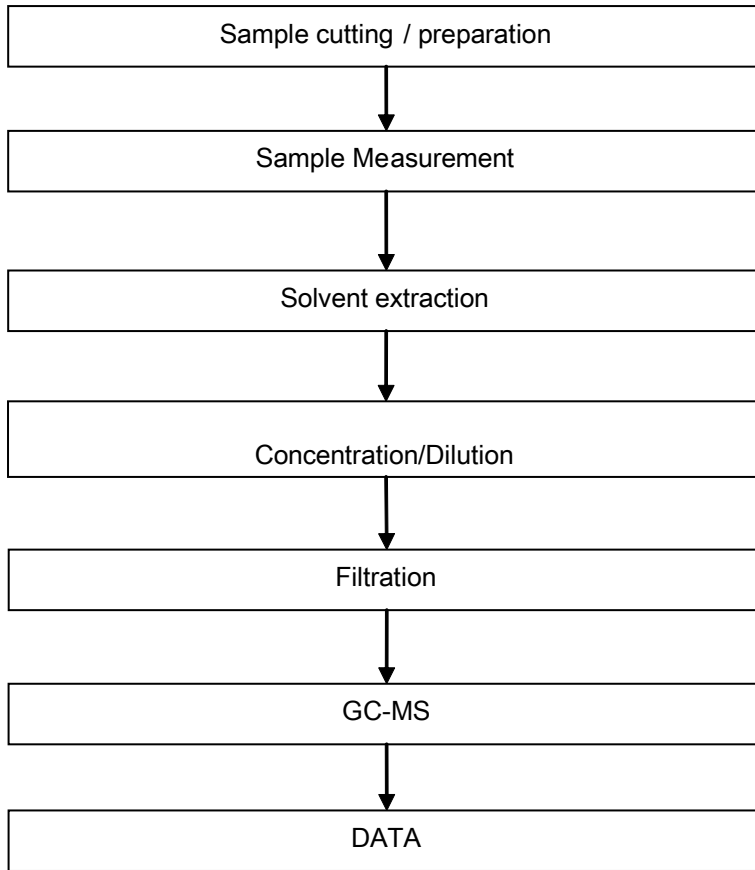

This document is issued by the Company subject to its General Conditions of Service printed overleaf, available on request or accessible at <http://www.sgs.com/en/Terms-and-Conditions.aspx> and, for electronic format documents, subject to Terms and Conditions for Electronic Documents at <http://www.sgs.com/en/Terms-and-Conditions/Terms-e-Documents.aspx>. Attention is drawn to the limitation of liability, indemnification and jurisdiction issues defined therein. Any holder of this document is advised that information contained hereon reflects the Company's findings at the time of its intervention only and within the limits of Client's instructions, if any. The Company's sole responsibility is to its Client and this document does not exonerate parties to a transaction from exercising all their rights and obligations under the transaction documents. This document cannot be reproduced except in full, without prior written approval of the Company. Any unauthorized alteration, forgery or falsification of the content or appearance of this document is unlawful and offenders may be prosecuted to the fullest extent of the law. Unless otherwise stated the results shown in this test report refer only to the sample(s) tested.

Sample photo:



SGS authenticate the photo on original report only

*** End of Report ***

测试报告

No. SHAEC1412283906

日期: 2014年07月03日 第1页,共4页

宁波兴业盛泰集团有限公司/宁波兴业鑫泰新型电子材料有限公司
浙江省慈溪经济开发区杭州湾新区金溪路2-9号

以下测试之样品是由申请者所提供及确认: 高锡磷青铜

SGS工作编号: SP14-020042 - SH
型号: C5210(QSn8.0-0.3) 5/3-111
成分: 铜基合金/Cu Sn P
样品接收日期: 2014年07月01日
测试周期: 2014年07月01日 - 2014年07月03日
测试要求: 根据客户要求测试
测试方法: 请参见下一页
测试结果: 请参见下一页
结论: 基于所送样品进行的测试, 镉、铅、汞、六价铬的测试结果符合欧盟RoHS指令2002/95/EC的重订指令2011/65/EU附录II的限值要求.

通标标准技术服务有限公司
授权签名



Marry Ma 马广媛
批准签署人

本报告是编号为SHAEC1412283905报告的中文版本.



This document is issued by the Company subject to its General Conditions of Service printed overleaf, available on request or accessible at <http://www.sgs.com/en/Terms-and-Conditions.aspx> and, for electronic format documents, subject to Terms and Conditions for Electronic Documents at <http://www.sgs.com/en/Terms-and-Conditions/Terms-e-Documents.aspx>. Attention is drawn to the limitation of liability, indemnification and jurisdiction issues defined therein. Any holder of this document is advised that information contained hereon reflects the Company's findings at the time of its intervention only and within the limits of Client's instructions, if any. The Company's sole responsibility is to its Client and this document does not exonerate parties to a transaction from exercising all their rights and obligations under the transaction documents. This document cannot be reproduced except in full, without prior written approval of the Company. Any unauthorized alteration, forgery or falsification of the content or appearance of this document is unlawful and offenders may be prosecuted to the fullest extent of the law. Unless otherwise stated the results shown in this test report refer only to the sample(s) tested.

Attention: To check the authenticity of testing /inspection report & certificate, please contact us at telephone: (86-755) 8307 1443, or email: CN.Doccheck@sgs.com

SGS-通标标准技术服务(上海)有限公司
Testing Center

3rd Building, No. 889 Yishan Road Xuhui District, Shanghai China 200233
中国·上海·徐汇区宜山路889号3号楼 邮编: 200233

t E&E (86-21) 61402553 f E&E (86-21) 64953679 www.sgsgroup.com.cn
HL: (86-21) 61402594 HL: (86-21) 54500353 e sgs.china@sgs.com

测试报告

No. SHAEC1412283906

日期: 2014年07月03日 第2页,共4页

测试结果:

测试样品描述:

样品编号	SGS样品ID	描述
SN1	SHA14-122839.003	铜色金属

备注:

- (1) 1 mg/kg = 0.0001%
- (2) MDL = 方法检测限
- (3) ND = 未检出 (< MDL)
- (4) "-" = 未规定

RoHS指令2011/65/EU

- 测试方法:
- (1) 参考IEC 62321-5:2013, 用ICP-OES测定镉的含量
 - (2) 参考IEC 62321-5:2013, 用ICP-OES测定铅的含量
 - (3) 参考IEC 62321-4:2013, 用ICP-OES测定汞的含量
 - (4) 参考IEC 62321:2008, 用点测试法/紫外-可见分光光度计比色法测定六价铬的含量

测试项目	限值	单位	MDL	003
镉 (Cd)	100	mg/kg	2	ND
铅(Pb)	1000	mg/kg	2	14
汞 (Hg)	1000	mg/kg	2	ND
六价铬(CrVI)	-	-	◇	阴性

备注:

- (1) 最大允许限值引用自指令2011/65/EU 附录II.
- (2) ◇点测试法:
阴性= 未检测到六价铬,阳性 = 检测到六价铬;
(当点测试结果为阴性或无法确定时,将采用沸水萃取法作进一步的结果验证.)
◇沸水萃取法:
阴性= 未检测到六价铬
阳性= 检测到六价铬;表明50 cm²表面积的被测试样品的沸水萃取液中六价铬的浓度等于或大于0.02 mg/kg
由于未获知样品的存储条件和生产日期,样品的六价铬测试结果仅能代表测试时样品含六价铬的状态.



This document is issued by the Company subject to its General Conditions of Service printed overleaf, available on request or accessible at <http://www.sgs.com/en/Terms-and-Conditions.aspx> and, for electronic format documents, subject to Terms and Conditions for Electronic Documents at <http://www.sgs.com/en/Terms-and-Conditions/Terms-e-Documents.aspx>. Attention is drawn to the limitation of liability, indemnification and jurisdiction issues defined therein. Any holder of this document is advised that information contained hereon reflects the Company's findings at the time of its intervention only and within the limits of Client's instructions, if any. The Company's sole responsibility is to its Client and this document does not exonerate parties to a transaction from exercising all their rights and obligations under the transaction documents. This document cannot be reproduced except in full, without prior written approval of the Company. Any unauthorized alteration, forgery or falsification of the content or appearance of this document is unlawful and offenders may be prosecuted to the fullest extent of the law. Unless otherwise stated the results shown in this test report refer only to the sample(s) tested.

Attention: To check the authenticity of testing /inspection report & certificate, please contact us at telephone: (86-755) 8307 1443, or email: CN.Doccheck@sgs.com

SGS-Standard Technical Services (Shanghai) Co., Ltd.
Testing Center

3rd Building, No. 889 Yishan Road Xuhui District, Shanghai China 200233
中国·上海·徐汇区宜山路889号3号楼 邮编: 200233

t E&E (86-21) 61402553 f E&E (86-21) 64953679 www.sgsgroup.com.cn
HL: (86-21) 61402594 HL: (86-21) 54500353 e sgs.china@sgs.com

附件

RoHS 测试流程图

- 1) 分析人员: 施青/汪红新/王晓艳
- 2) 项目负责人: 张春华
- 3) 样品按照下述流程被完全消解 (六价铬测试除外)

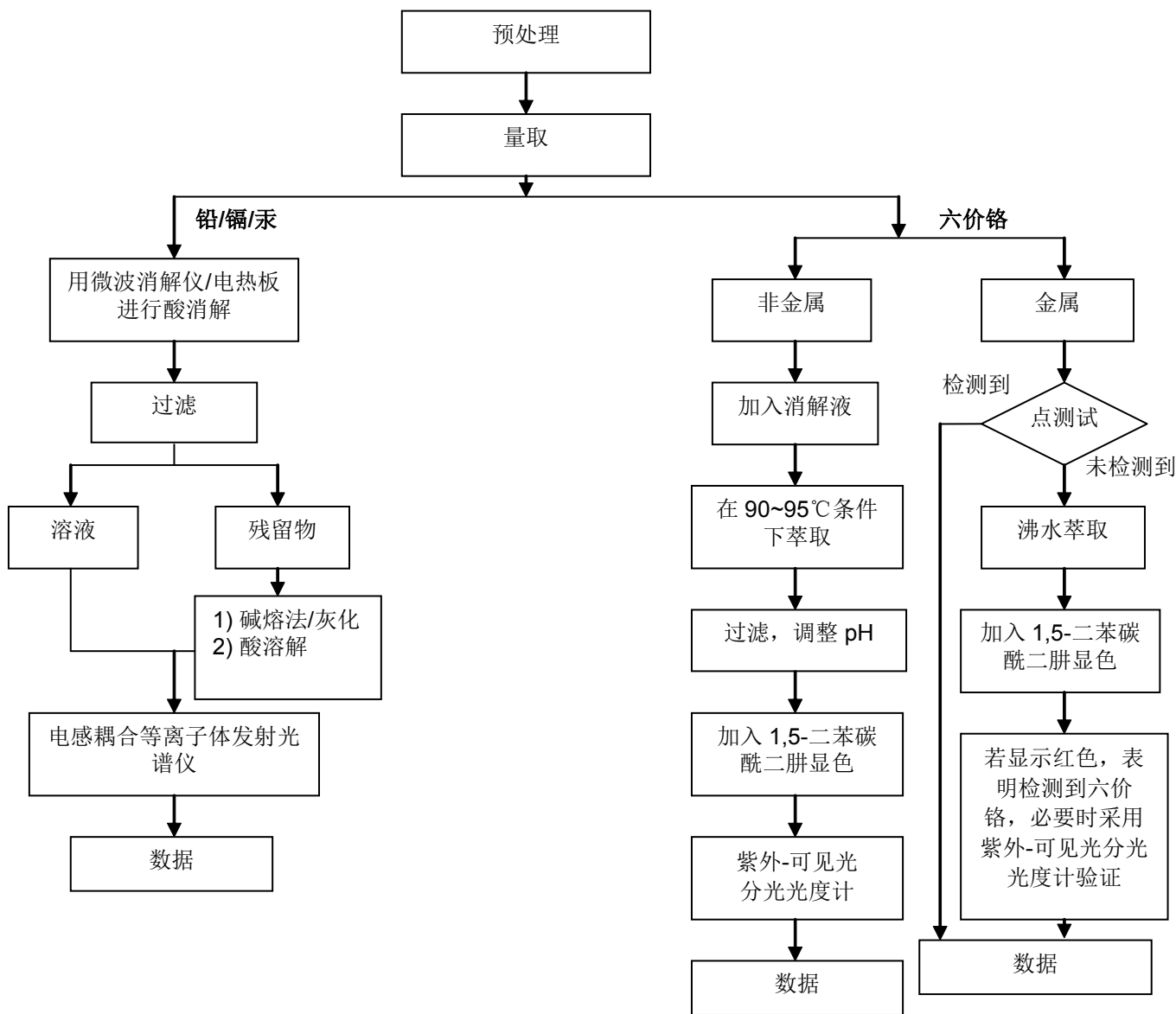

This document is issued by the Company subject to its General Conditions of Service printed overleaf, available on request or accessible at <http://www.sgs.com/en/Terms-and-Conditions.aspx> and, for electronic format documents, subject to Terms and Conditions for Electronic Documents at <http://www.sgs.com/en/Terms-and-Conditions/Terms-e-Documents.aspx>. Attention is drawn to the limitation of liability, indemnification and jurisdiction issues defined therein. Any holder of this document is advised that information contained hereon reflects the Company's findings at the time of its intervention only and within the limits of Client's instructions, if any. The Company's sole responsibility is to its Client and this document does not exonerate parties to a transaction from exercising all their rights and obligations under the transaction documents. This document cannot be reproduced except in full, without prior written approval of the Company. Any unauthorized alteration, forgery or falsification of the content or appearance of this document is unlawful and offenders may be prosecuted to the fullest extent of the law. Unless otherwise stated the results shown in this test report refer only to the sample(s) tested.

Attention: To check the authenticity of testing / inspection report & certificate, please contact us at telephone: (86-755) 8307 1443, or email: CN.Doccheck@sgs.com

样品照片:



此照片仅限于随SGS正本报告使用

*** 报告完 ***



测试报告

No. CANEC1316336002

日期: 2013年10月28日 第1页,共4页

深圳市多鑫实业有限公司
深圳市宝安区松岗镇江边工业区

以下测试之样品是由申请者所提供及确认: 金

SGS工作编号: CP13-054392 - GZ
样品接收日期: 2013年10月23日
测试周期: 2013年10月23日 - 2013年10月28日
测试要求: 根据客户要求测试
测试方法: 请参见下一页
测试结果: 请参见下一页
结论: 基于所送样品进行的测试, 镉、铅、汞、六价铬的测试结果符合欧盟RoHS指令2002/95/EC的重订指令2011/65/EU附录II的限值要求。

通标标准技术服务有限公司
授权签名



Merry Lv 吕爱凤
批准签署人

备注: 根据客户申请, SGS出具了此中文报告, 英文版本可根据客户要求提供. (The Chinese test report is issued according to the applicant's request. The English version is available from SGS if further needed)

This document is issued by the Company subject to its General Conditions of Service printed overleaf, available on request or accessible at <http://www.sgs.com/en/Terms-and-Conditions.aspx> and, for electronic format documents, subject to Terms and Conditions for Electronic Documents at <http://www.sgs.com/en/Terms-and-Conditions/Terms-e-Document.aspx>. Attention is drawn to the limitation of liability, indemnification and jurisdiction issues defined therein. Any holder of this document is advised that information contained herein reflects the Company's findings at the time of its intervention only and within the limits of Client's instructions, if any. The Company's sole responsibility is to its Client and this document does not exonerate parties to a transaction from exercising all their rights and obligations under the transaction documents. This document cannot be reproduced except in full, without prior written approval of the Company. Any unauthorized alteration, forgery or falsification of the content or appearance of this document is unlawful and offenders may be prosecuted to the fullest extent of the law. Unless otherwise stated the results shown in this test report refer only to the sample(s) tested.

测试报告

No. CANEC1316336002

日期: 2013年10月28日 第2页,共4页

测试结果:

测试样品描述:

样品编号	SGS样品ID	描述
1	CAN13-163360.002	带金色镀层的金属

备注:

- (1) 1 mg/kg = 1 ppm = 0.0001%
- (2) MDL = 方法检测限
- (3) ND = 未检出 (< MDL)
- (4) "-" = 未规定

RoHS指令2011/65/EU

- 测试方法:
- (1)参考IEC 62321-5:2013, 用ICP-OES测定镉的含量
 - (2)参考IEC 62321-5:2013, 用ICP-OES测定铅的含量
 - (3)参考IEC 62321-4:2013, 用ICP-OES测定汞的含量
 - (4)参考IEC 62321:2008, 用点测试法/紫外-可见分光光度计比色法测定六价铬的含量

测试项目	限值	单位	MDL	002
镉 (Cd)	100	mg/kg	2	15
铅 (Pb)	1,000	mg/kg	2	89
汞 (Hg)	1,000	mg/kg	2	ND
六价铬(Cr(VI))	-	-	◇	阴性

备注:

- (1) 最大允许极限值引用自指令2011/65/EU 附录II.
- (2) ◇点测试法:
 阴性= 未检测到六价铬, 阳性= 检测到六价铬;
 (当点测试结果为阴性或无法确定时,将采用沸水萃取法作进一步的结果验证.)
 ◇沸水萃取法:
 阴性= 未检测到六价铬
 阳性= 检测到六价铬; 表明50 cm²表面积的被测试样品的沸水萃取液中六价铬的浓度等于或大于0.02 mg/kg
 由于未获知样品的存储条件和生产日期, 样品的六价铬测试结果仅能代表测试时样品含六价铬的状态。

This document is issued by the Company subject to its General Conditions of Service printed overleaf, available on request or accessible at <http://www.sgs.com/en/Terms-and-Conditions.aspx> and, for electronic format documents, subject to Terms and Conditions for Electronic Documents at <http://www.sgs.com/en/Terms-and-Conditions/Terms-e-Document.aspx>. Attention is drawn to the limitation of liability, indemnification and jurisdiction issues defined therein. Any holder of this document is advised that information contained herein reflects the Company's findings at the time of its intervention only and within the limits of Client's instructions, if any. The Company's sole responsibility is to its Client and this document does not exonerate parties to a transaction from exercising all their rights and obligations under the transaction documents. This document cannot be reproduced except in full, without prior written approval of the Company. Any unauthorized alteration, forgery or falsification of the content or appearance of this document is unlawful and offenders may be prosecuted to the fullest extent of the law. Unless otherwise stated the results shown in this test report refer only to the sample(s) tested.

附件

RoHS 测试流程图

- 1) 分析人员: 曹阳
- 2) 项目负责人: 余奕东
- 3) 样品按照下述流程被完全消解 (六价铬测试除外)。

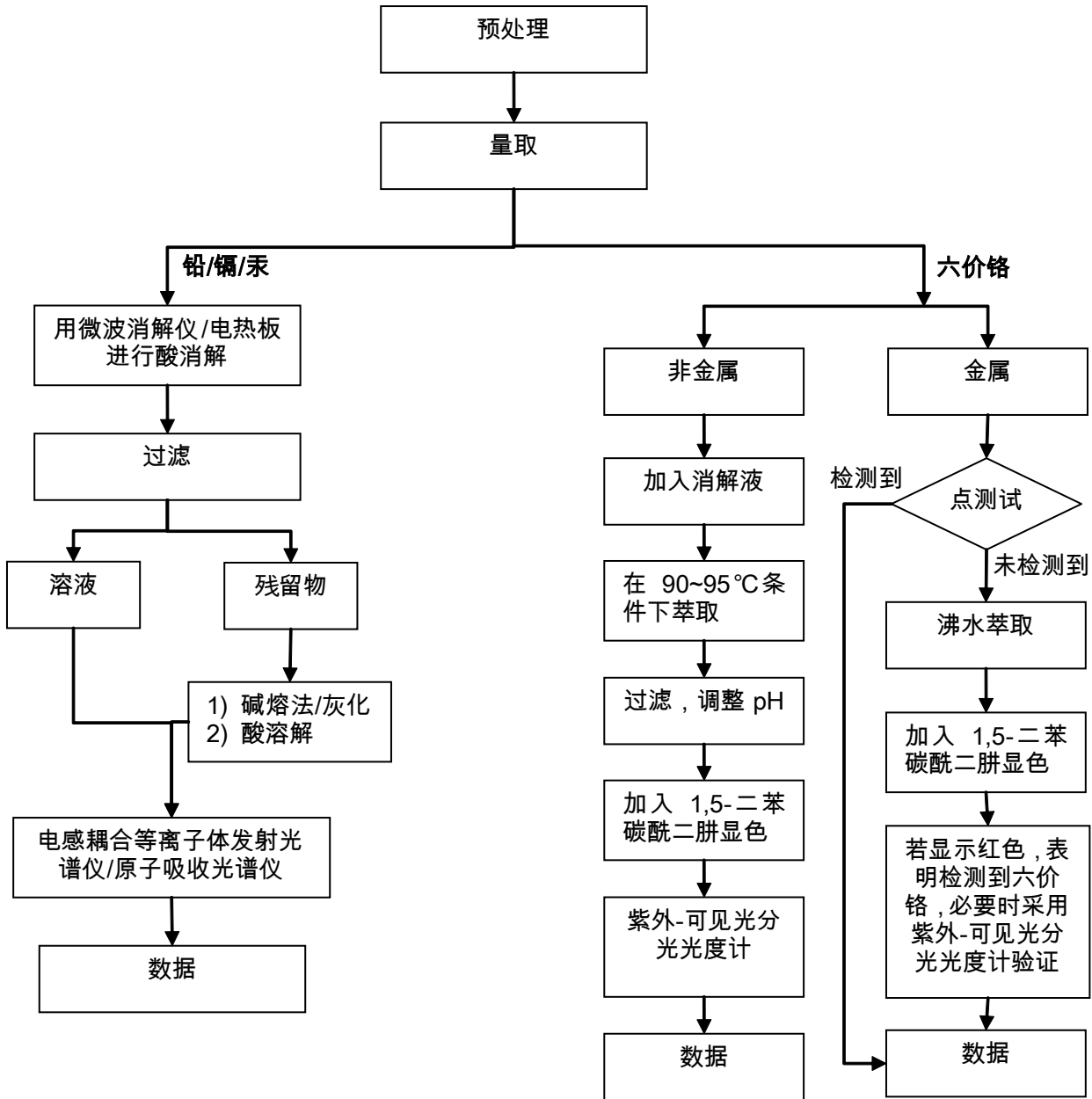

This document is issued by the Company subject to its General Conditions of Service printed overleaf, available on request or accessible at <http://www.sgs.com/en/Terms-and-Conditions.aspx> and, for electronic format documents, subject to Terms and Conditions for Electronic Documents at <http://www.sgs.com/en/Terms-and-Conditions/Terms-e-Document.aspx>. Attention is drawn to the limitation of liability, indemnification and jurisdiction issues defined therein. Any holder of this document is advised that information contained herein reflects the Company's findings at the time of its intervention only and within the limits of Client's instructions, if any. The Company's sole responsibility is to its Client and this document does not exonerate parties to a transaction from exercising all their rights and obligations under the transaction documents. This document cannot be reproduced except in full, without prior written approval of the Company. Any unauthorized alteration, forgery or falsification of the content or appearance of this document is unlawful and offenders may be prosecuted to the fullest extent of the law. Unless otherwise stated the results shown in this test report refer only to the sample(s) tested.

样品照片:



此照片仅限于随SGS正本报告使用

*** 报告完 ***

This document is issued by the Company subject to its General Conditions of Service printed overleaf, available on request or accessible at <http://www.sgs.com/en/Terms-and-Conditions.aspx> and, for electronic format documents, subject to Terms and Conditions for Electronic Documents at <http://www.sgs.com/en/Terms-and-Conditions/Terms-e-Document.aspx>. Attention is drawn to the limitation of liability, indemnification and jurisdiction issues defined therein. Any holder of this document is advised that information contained herein reflects the Company's findings at the time of its intervention only and within the limits of Client's instructions, if any. The Company's sole responsibility is to its Client and this document does not exonerate parties to a transaction from exercising all their rights and obligations under the transaction documents. This document cannot be reproduced except in full, without prior written approval of the Company. Any unauthorized alteration, forgery or falsification of the content or appearance of this document is unlawful and offenders may be prosecuted to the fullest extent of the law. Unless otherwise stated the results shown in this test report refer only to the sample(s) tested.